

5400 SERIES



SAE Class 2 LED Minibar

BACK-UP
ALARMS

WARNING
LIGHTS

These LED minibars provide a compact yet powerful warning solution providing the flexibility of either permanent or vacuum-magnet mounting. Featuring 12-24 VDC operation, the 5412 uses high intensity LEDs and reflective technology to maximize light output. Users can select from 18 flash patterns, either via trigger wire on permanent mount models or cigarette plug switch on magnetic models.

Features

- Eight LED reflector modules, each comprising three LEDs provide high intensity light output
- Choice of 18 flash patterns
- Cigarette plug with on/off and flash pattern selection switch (vacuum-magnet only)
- Polycarbonate base & low profile lens
- SAE J845 Class II, CE, e
- Warranty: 3 years

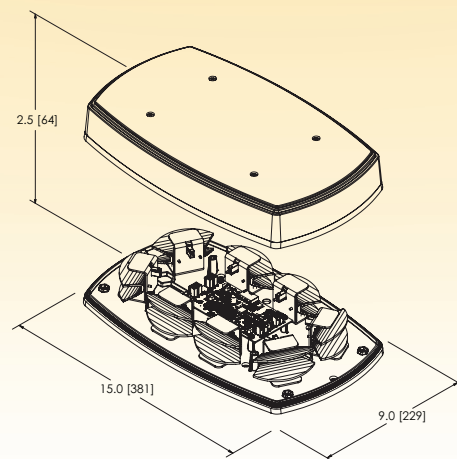

Flash Patterns

- | | | |
|---------------|---------------------------------------|-----------------------------------|
| 1 Quad | 7 Burst | 13 Quint-hold, Diagonal Alternate |
| 2 Double | 8 Quad, Alternate Side-to-Side | 14 Fast Rotate |
| 3 Fast Double | 9 Quad, Diagonal Alternate | 15 Rotate / Quad |
| 4 Slow Quad | 10 Double, Alternate Side-to-Side | 16 Wave Rotate |
| 5 Slow Double | 11 Double, Diagonal Alternate | 17 Random |
| 6 Quint-hold | 12 Quint-hold, Alternate Side-to-Side | 18 Steady On |

Parts & Accessories

- Amber Lens: LA5412
- Clear Lens: LC5412
- Vac-Mag Mount Kit: MKS5412

Model	Lens Color	Illumination	Voltage	Amps	Mounting	SAE
5412A	Amber	Amber	12-24	3.5	Permanent	2
5412CA	Clear	Amber	12-24	3.5	Vacuum-Magnet	2
5412A-VM	Amber	Amber	12-24	3.5	Permanent	2
5412CA-VM	Clear	Amber	12-24	3.5	Vacuum-Magnet	2

