

Preco

INSTALLATION INSTRUCTIONS TS7710 STROBE TAIL LIGHT VEHICLE POWER-LINE SYNCHRONIZED PATENT PENDING

This is a Receive-only strobe intended as either the RIGHT REAR or LEFT REAR strobe in a multiple strobe system. This unit will default to a double flash without either a CT7730 Controller Strobe or a DM7810 Dash Mount Controller connected to the same wires that provide power to this strobe (PATENT PENDING). This strobe has the word "LEFT" labeled on its housing to indicate its functional position in the system. See below for readjustment instructions.

DANGER! BEFORE REMOVING THE STROBE LIGHT LENS, WAIT 5 MINUTES AFTER THE POWER TO THE STROBE HAS BEEN SHUT OFF. THE STROBE POWER SUPPLY CONTAINS LETHAL VOLTAGES WHICH MUST DISCHARGE BEFORE HANDLING THE CIRCUITRY.

STROBE LIGHT INSTALLATION:

The Strobe Light is intended for commercial use and should be installed and maintained by qualified personnel. Position the unit to avoid damage and protect as required. Insure the location provides for function as intended and does not interfere with operator's safe operation of the vehicle.

IN CASE OF TROUBLE:

If the Strobe Light stops operating suddenly, first insure it is getting power, 10VDC min. to 33VDC max. If the voltage to the strobe is not within this range, the strobe will not flash. If the power to the Strobe Light is correct, then either the Flash Tube may need replacement (see below), or the internal Power Supply may need replacement. To replace the Power Supply, turn OFF the Strobe Light power AND WAIT 5 (FIVE) MINUTES. Remove the lens and inspect the Flash Tube and Power Supply. If any burned or extremely corroded areas are visible, replace the Power Supply and the Flash Tube. Reassemble the Strobe Light. Always replace the Flash Tube when the Power Supply is replaced. Follow the directions below.

REPLACEMENT OF FLASH TUBE:

The Flash Tube will darken with operation and eventually need replacement. Turn OFF the Strobe Light AND WAIT 5 (FIVE) MINUTES. Remove the Lens and set aside. Remove the Flash Tube Assembly, squeezing inward on the black plastic body tabs and pulling straight upward, from the Power Supply. Do not rock the assembly or grasp the glass tube. Inspect the tube pins and supply sockets for corrosion, clean with isopropyl alcohol if necessary. If the corrosion is extreme, replace the Power Supply. Plug a new Flash Tube Assembly into the Power Supply, insuring the tabs positively latch. Note the Tube Assembly is polarized and will only plug in one direction. Clean the inside of the Lens and the Power Supply with isopropyl alcohol. Allow parts to dry completely and re-assemble the Lens. Be sure to tighten the screws to hold the lens tight against the strobe housing.

STROBE LIGHT SPECIFICATIONS:

1.0 Introduction

This unit is packaged in a durable polycarbonate housing with a removable polycarbonate lens. The modular vibration-resistant power supply and the flash tube are both field-replaceable. This Strobe Light is designed for 12 & 24 Volt Systems without modifications or adjustment.

2.0 Physical Specifications-see Outline Drawing

- 2.1 Electronics: Solid-state shock-mounted PC assembly (via the large rubber grommet).
- 2.2 Housing: Polycarbonate.
- 2.3 Lens: Polycarbonate, screws onto the housing.
- 2.4 Weight: 12 oz
- 2.5 Size: 3-3/8" W x 7-1/2" L x 3-3/4" deep
- 2.6 Mounting: Pressure-fits into a Tail-Light well sized as shown here:

3.0 Electrical Specifications

- 3.1 Input Voltage: 12 & 24 Volt Systems (10 VDC to 33 VDC)
- 3.2 Input Current: 1 Amp
- 3.3 Spike Protection: +50, -400 Volts
- 3.4 Polarity: Positive or negative ground, polarity protected.
- 3.5 Connection: Red positive, black negative 18 AWG 8" (203mm) wires. Connection hardware is included.
- 3.6 Fuse Protection: None - external 5 Amp fuse recommended.

4.0 Output Specifications

- 4.1 Energy Level: 4 Joules.
- 4.2 Flash Rate: 60 to 120 flash cycles per minute.

5.0 Additional Specifications

- 5.1 Warranty: 24 months limited warranty.
Flash tube assembly 6 months limited warranty.
- 5.2 Operating Temperature Range: -30°C (-22°F) to +50°C (122°F).
- 5.3 Cleaning: Unit may be exposed to spray wash.
- 5.4 Flash-Tube and Power Supply both easily replaceable.

6.0 Options: See our catalog for a list of accessories.

7.0 ADJUSTING STROBE SEQUENCE POSITION TO EITHER LEFT (TS7710_) OR RIGHT (TS7710_)

- 7.1 Turn off power to the strobe, and WAIT 5 MINUTES. This is important to avoid a dangerous electrical shock.
- 7.2 Remove the lens and look on the circuit board for a small rotary switch that looks like the one shown here to the right.
- 7.3 Using a 1/16" screwdriver, turn the center of the switch such that the arrowhead end of the slot points to "4" for RIGHT, or to "0" for LEFT.
- 7.4 Replace the lens and reapply power to the strobe.

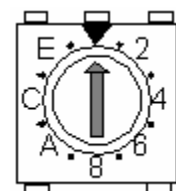
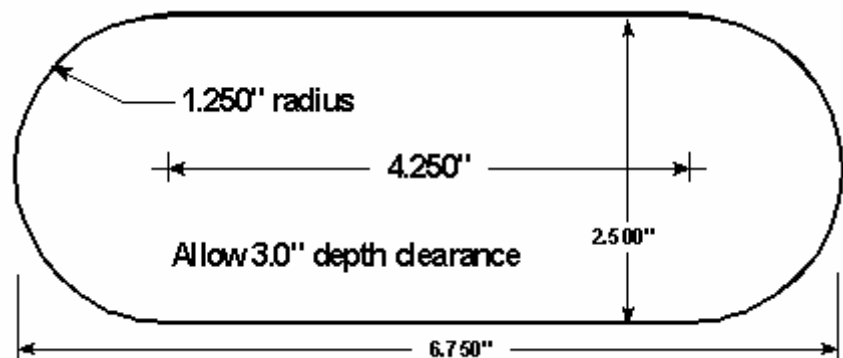

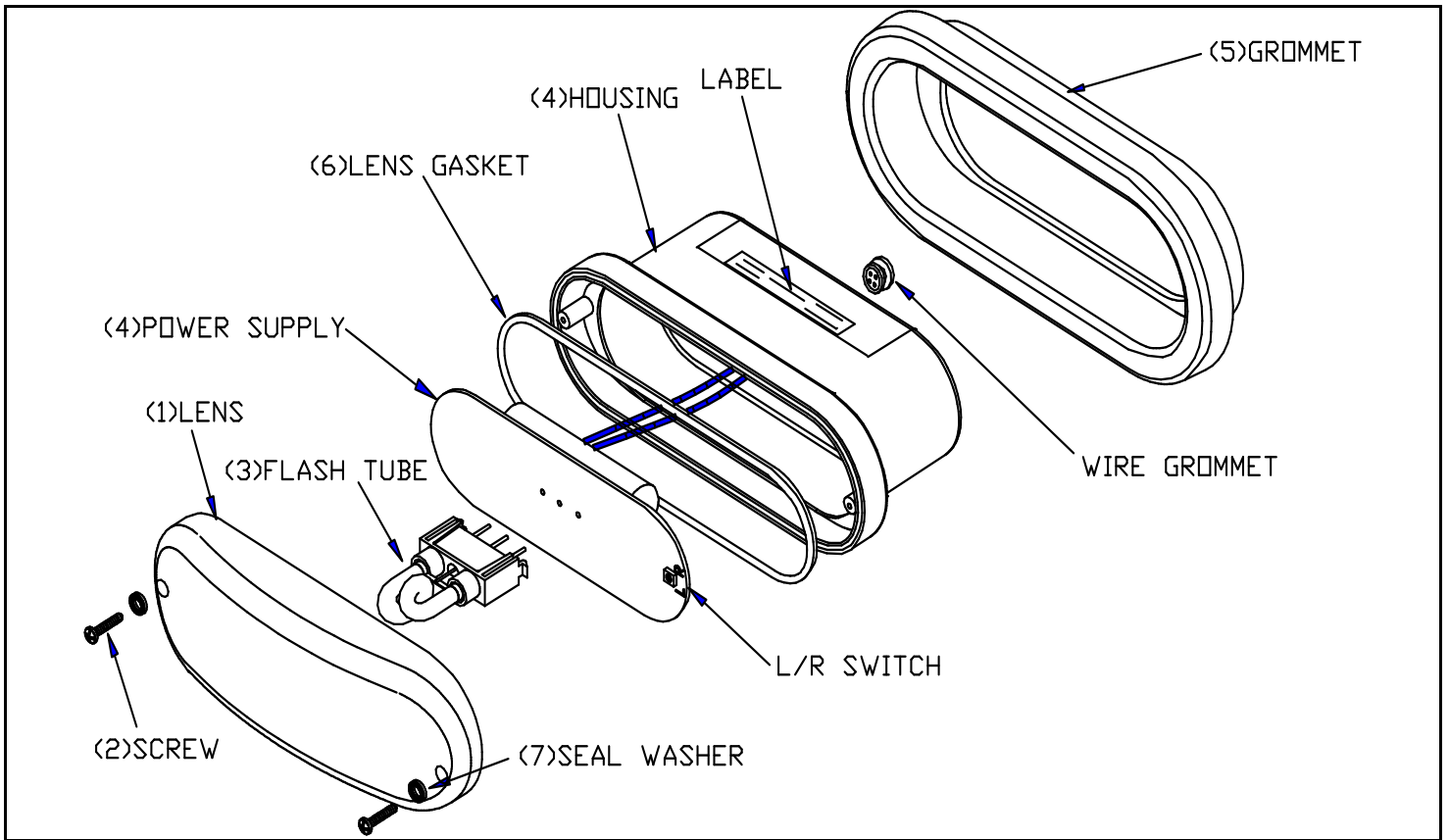

8.0 REPLACEMENT PARTS SHOWN IN DRAWING:

1 Polycarbonate Lens, Amber	LA7710
(other colors available upon request)	
2 #6-20 x 5/8" Lens Mounting Screw (2 ea)	SC7710
3 Strobe Flash Tube Assembly (Polarized)	FT3864A
4 Housing & Strobe Power Supply ass'y	PS7710
5 Grommet	GT7710
6 Lens Gasket	GL7710
7 Seal Washer (2ea)	SW7710

PRECO LIMITED WARRANTY AND LIMITATION OF LIABILITY

Preco warrants that on the Date of Purchase this Product will conform to Preco's published specifications for the product, which are available from Preco on request, and Preco warrants that the product is free from defects in materials and workmanship. This Limited Warranty extends for twenty four (24) months from the date of manufacture. Preco will, at its option, repair or replace any product found by Preco to be defective and subject to this Limited Warranty.

This Limited Warranty does not apply to parts or products that are misused; abused; modified; damaged by accident, fire or other hazard; improperly installed or operated; or not maintained in accordance with the maintenance procedures set forth in Preco's Installation and Operating Instructions.

To obtain warranty service, you must ship the product(s) to the specified Preco location within thirty (30) days from expiration of the warranty period. You must call for a return authorization number. You must prepay shipping charges and use the original shipping container or equivalent. Return shipping charges within the United States, Canada, and Puerto Rico will be paid by Preco.

EXCLUSION OF OTHER WARRANTIES: PRECO MAKES NO OTHER WARRANTIES, EXPRESS, IMPLIED OR STATUTORY. THE IMPLIED WARRANTIES FOR MERCHANTABILITY OR FITNESS FOR A PARTICULAR PURPOSE ARE HEREBY EXCLUDED AND SHALL NOT APPLY TO THE PRODUCT. BUYER'S SOLE AND EXCLUSIVE REMEDY IN CONTRACT, TORT OR UNDER ANY OTHER THEORY AGAINST PRECO RESPECTING THE PRODUCT AND ITS USE SHALL BE THE REPLACEMENT OR REPAIR OF THE PRODUCT AS DESCRIBED ABOVE.

LIMITATION OF LIABILITY: IN THE EVENT OF LIABILITY FOR DAMAGES ARISING OUT OF THIS LIMITED WARRANTY OR ANY OTHER CLAIM RELATED TO PRECO PRODUCTS, PRECO'S LIABILITY FOR DAMAGES SHALL BE LIMITED TO THE AMOUNT PAID FOR THE PRODUCT AT THE TIME OF ORIGINAL PURCHASE. IN NO EVENT SHALL PRECO BE LIABLE FOR LOST PROFITS, THE COST OF SUBSTITUTE EQUIPMENT OR LABOR, PROPERTY DAMAGE, OR OTHER SPECIAL, CONSEQUENTIAL OR INCIDENTAL DAMAGES BASED UPON ANY CLAIM FOR BREACH OF CONTRACT, NEGLIGENCE OR OTHER CLAIM, EVEN IF PRECO OR A PRECO REPRESENTATIVE HAS BEEN ADVISED OF THE POSSIBILITY OF SUCH DAMAGES. Preco shall have no further obligation or liability with respect to the product or its sale, operation and use, and Preco neither assumes nor authorizes the assumption of any other obligation or liability in connection with such product.

This Limited Warranty gives you specific legal rights, and you may also have other legal rights which vary from state to state. Some states do not allow the exclusion or limitation of incidental or consequential damages, so the above exclusion or limitation may not apply to you.

Any oral statements or representations about the product which may have been made by salesmen or Preco representatives do not constitute warranties. This Limited Warranty may not be amended, modified or enlarged, except by a written agreement signed by an authorized official of Preco which expressly refers to this Limited Warranty.